



Professional HEAVY DUTY

GCM 18V-216 D

Robert Bosch Power Tools GmbH
70538 Stuttgart
GERMANY

www.bosch-pt.com

1 609 92A 7BM (2026.03) PS / 33



1 609 92A 7BM

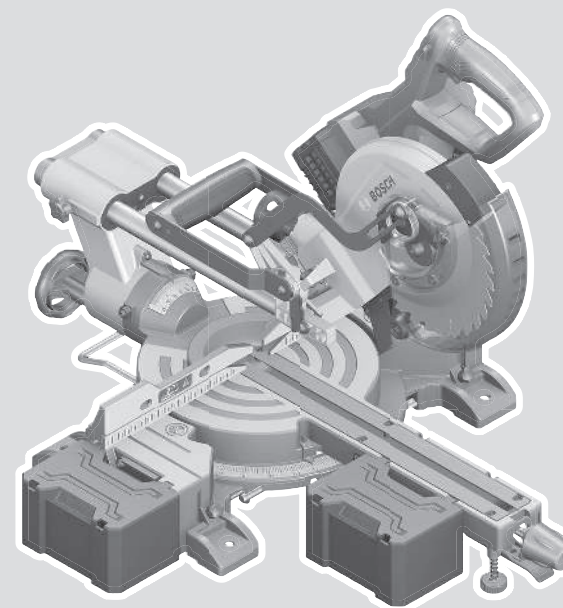

en Original instructions









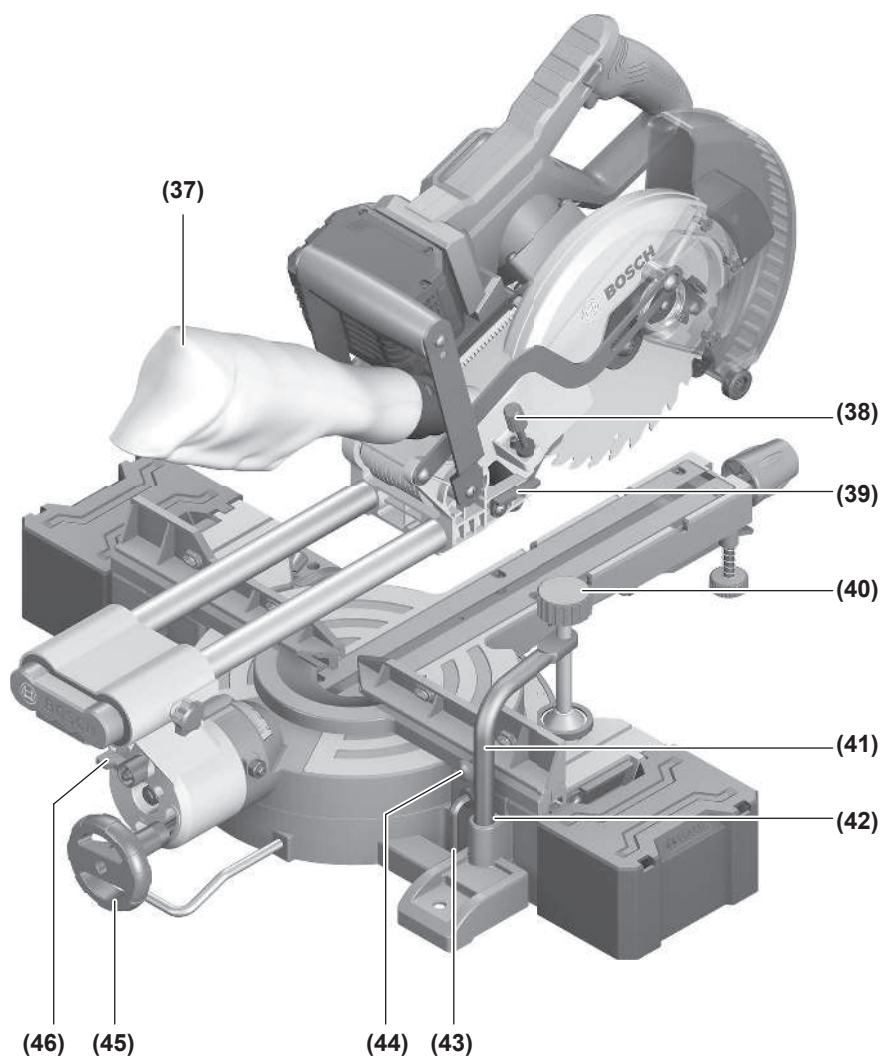

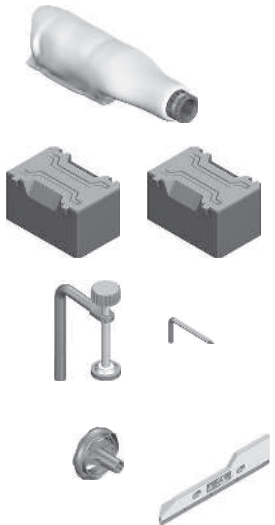

A1

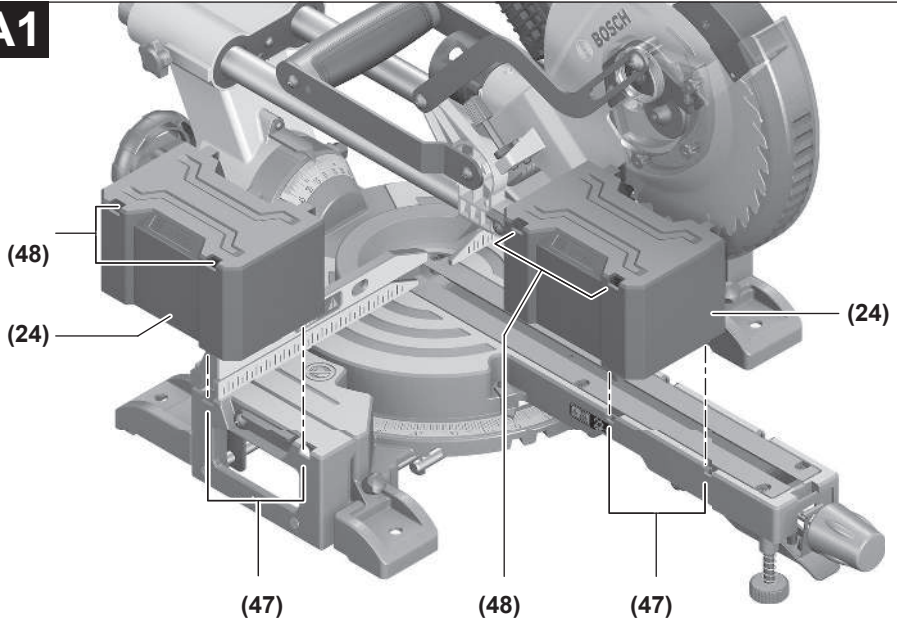

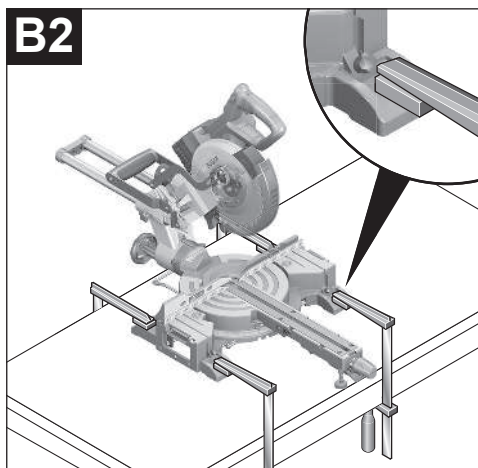
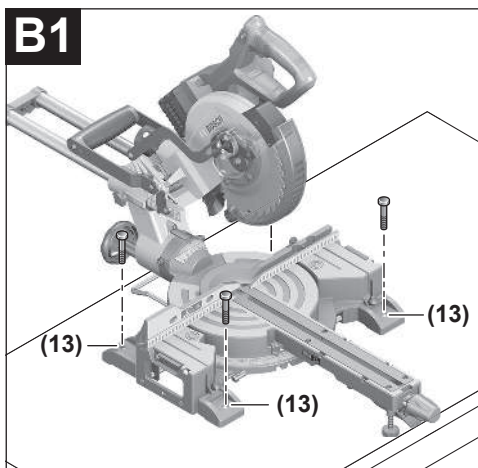
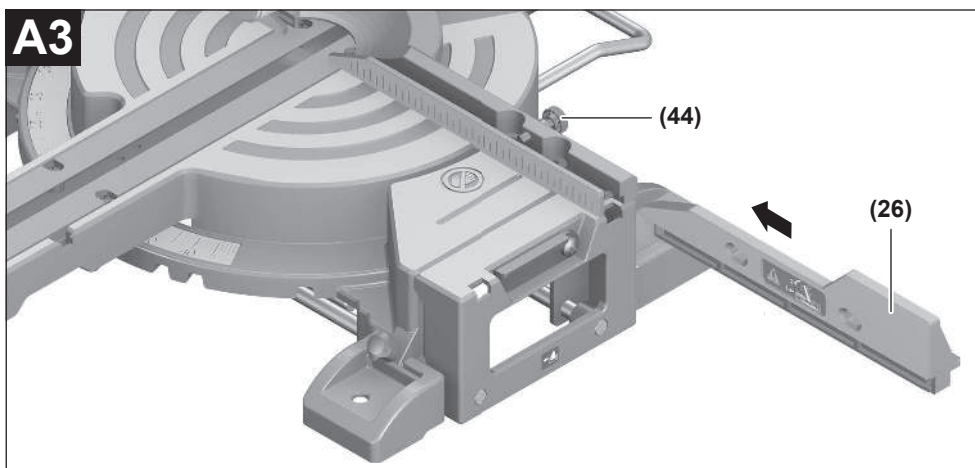
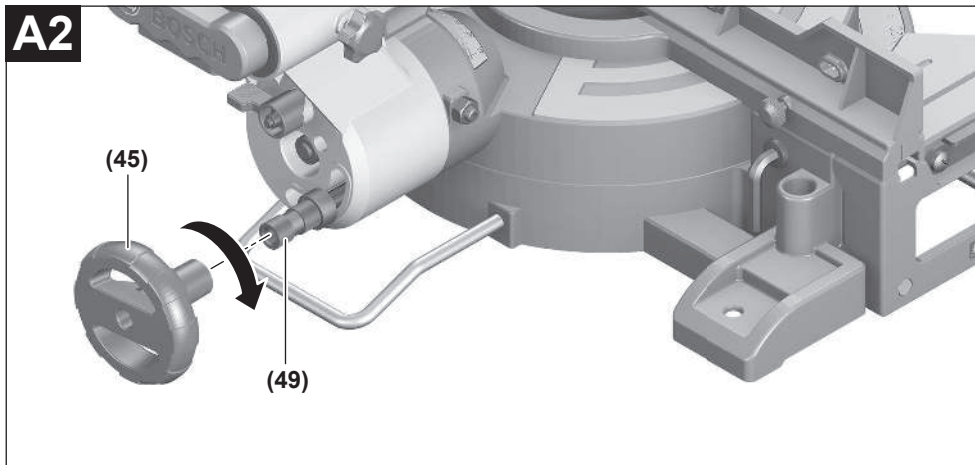



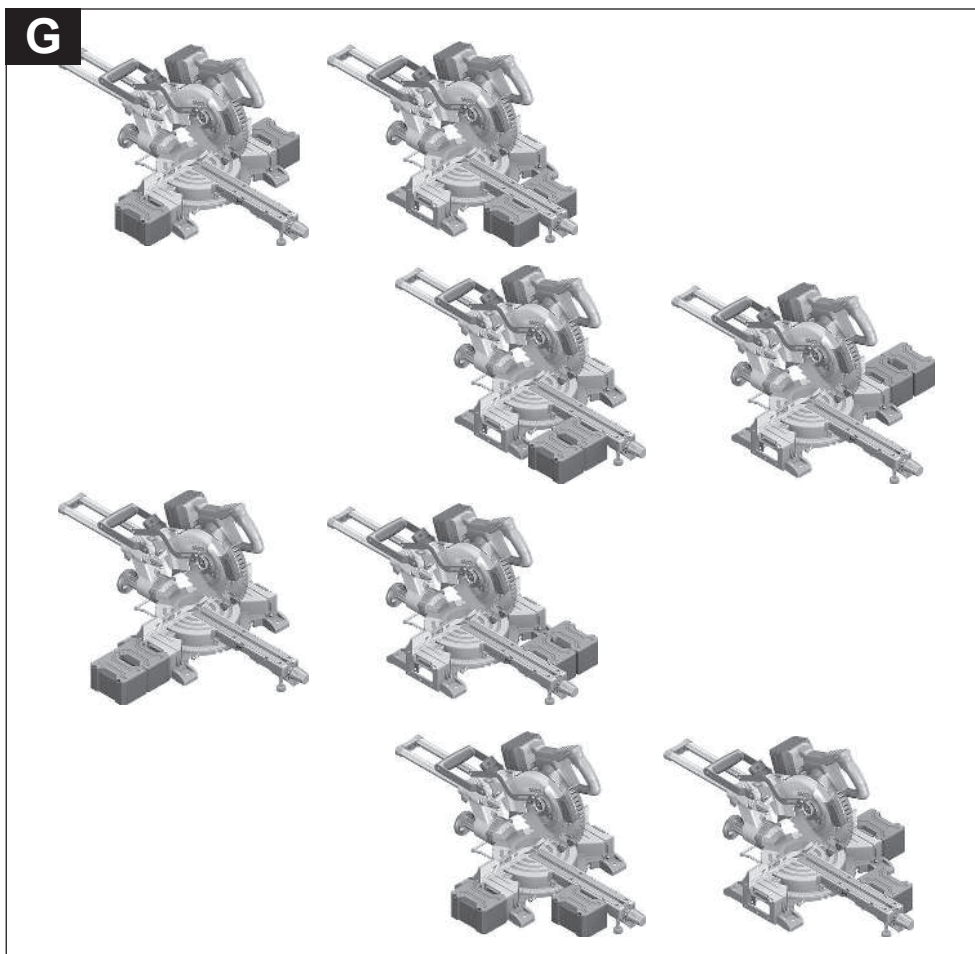
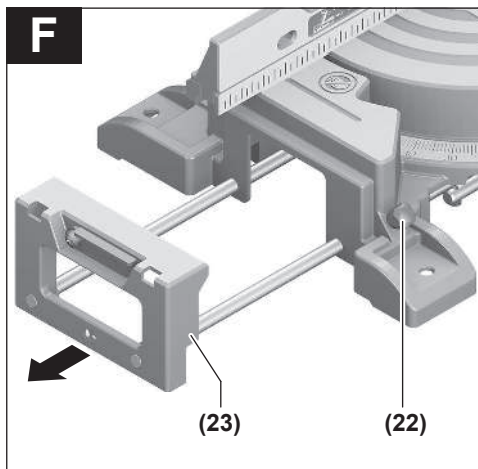
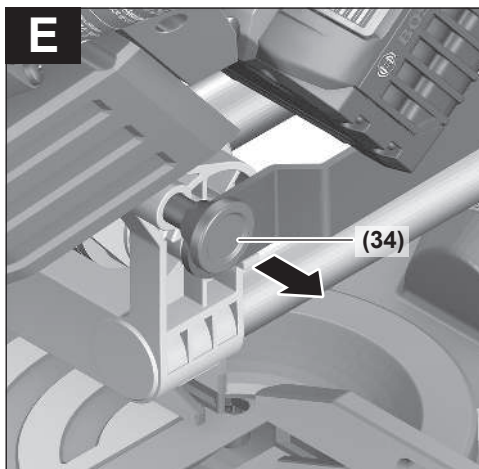





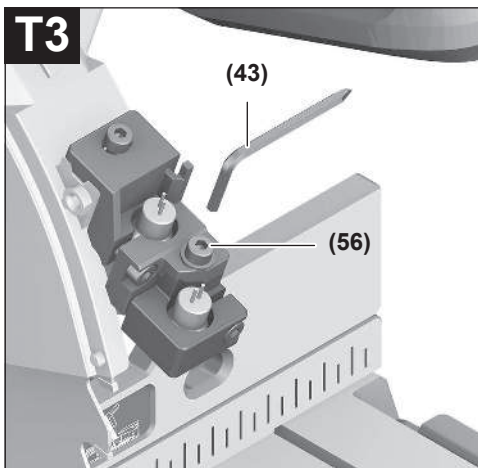
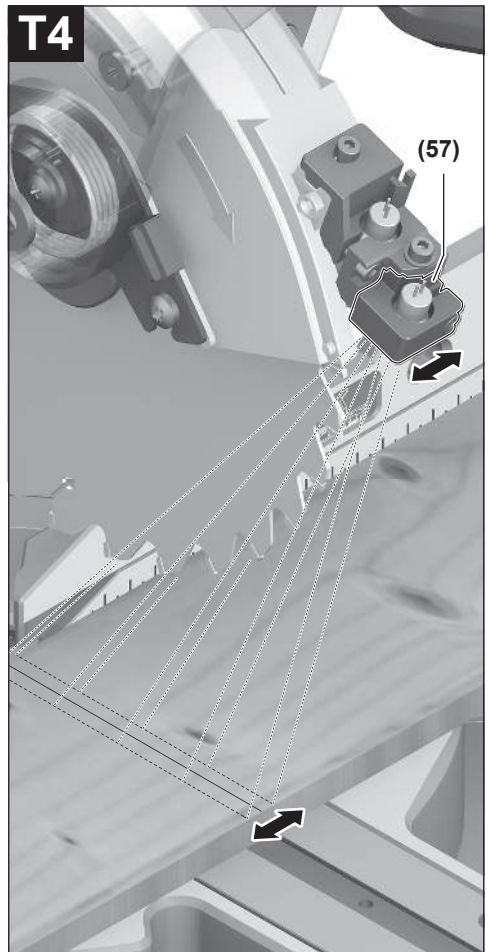
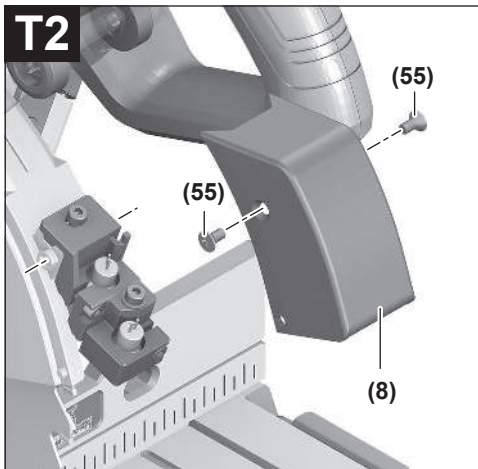
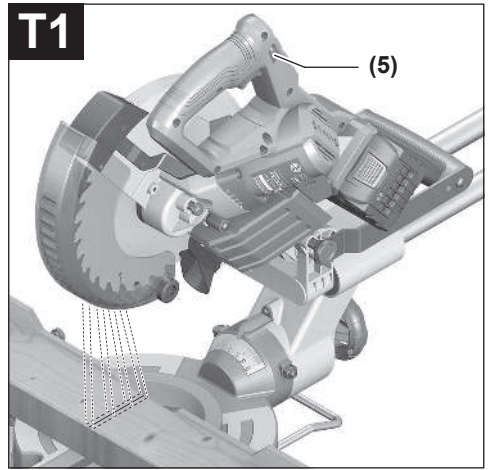
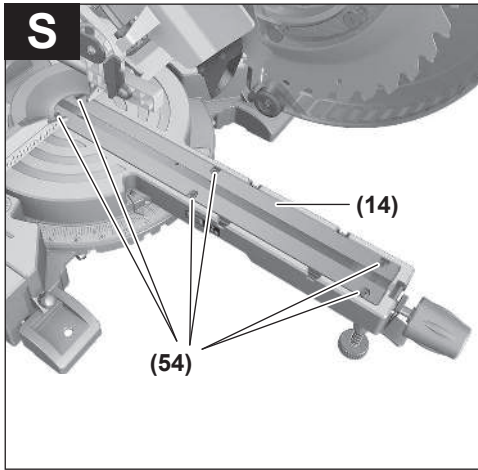



English

Safety instructions

General Power Tool Safety Warnings

⚠ WARNING Read all safety warnings, instructions, illustrations and specifications provided with this power tool. Failure to follow all instructions listed below may result in electric shock, fire and/or serious injury.

Save all warnings and instructions for future reference.

The term "power tool" in the warnings refers to your mains-operated (corded) power tool or battery-operated (cordless) power tool.

Work area safety

- ▶ **Keep work area clean and well lit.** Cluttered or dark areas invite accidents.
- ▶ **Do not operate power tools in explosive atmospheres, such as in the presence of flammable liquids, gases or dust.** Power tools create sparks which may ignite the dust or fumes.
- ▶ **Keep children and bystanders away while operating a power tool.** Distractions can cause you to lose control.

Electrical safety

- ▶ **Do not expose power tools to rain or wet conditions.** Water entering a power tool will increase the risk of electric shock.

Personal safety

- ▶ **Stay alert, watch what you are doing and use common sense when operating a power tool. Do not use a power tool while you are tired or under the influence of drugs, alcohol or medication.** A moment of inattention while operating power tools may result in serious personal injury.
- ▶ **Use personal protective equipment. Always wear eye protection.** Protective equipment such as a dust mask, non-skid safety shoes, hard hat or hearing protection used for appropriate conditions will reduce personal injuries.
- ▶ **Prevent unintentional starting. Ensure the switch is in the off-position before connecting to power source and/or battery pack, picking up or carrying the tool.** Carrying power tools with your finger on the switch or engaging power tools that have the switch on invites accidents.
- ▶ **Remove any adjusting key or wrench before turning the power tool on.** A wrench or a key left attached to a rotating part of the power tool may result in personal injury.
- ▶ **Do not overreach. Keep proper footing and balance at all times.** This enables better control of the power tool in unexpected situations.

- ▶ **Dress properly. Do not wear loose clothing or jewellery. Keep your hair and clothing away from moving parts.** Loose clothes, jewellery or long hair can be caught in moving parts.
- ▶ **If devices are provided for the connection of dust extraction and collection facilities, ensure these are connected and properly used.** Use of dust collection can reduce dust-related hazards.
- ▶ **Do not let familiarity gained from frequent use of tools allow you to become complacent and ignore tool safety principles.** A careless action can cause severe injury within a fraction of a second.

Power tool use and care

- ▶ **Do not force the power tool. Use the correct power tool for your application.** The correct power tool will do the job better and safer at the rate for which it was designed.
- ▶ **Do not use the power tool if the switch does not turn it on and off.** Any power tool that cannot be controlled with the switch is dangerous and must be repaired.
- ▶ **Disconnect the plug from the power source and/or remove the battery pack, if detachable, from the power tool before making any adjustments, changing accessories, or storing power tools.** Such preventive safety measures reduce the risk of starting the power tool accidentally.
- ▶ **Store idle power tools out of the reach of children and do not allow persons unfamiliar with the power tool or these instructions to operate the power tool.** Power tools are dangerous in the hands of untrained users.
- ▶ **Maintain power tools and accessories. Check for misalignment or binding of moving parts, breakage of parts and any other condition that may affect the power tool's operation. If damaged, have the power tool repaired before use.** Many accidents are caused by poorly maintained power tools.
- ▶ **Keep cutting tools sharp and clean.** Properly maintained cutting tools with sharp cutting edges are less likely to bind and are easier to control.
- ▶ **Use the power tool, accessories and tool bits etc. in accordance with these instructions, taking into account the working conditions and the work to be performed.** Use of the power tool for operations different from those intended could result in a hazardous situation.
- ▶ **Keep handles and grasping surfaces dry, clean and free from oil and grease.** Slippery handles and grasping surfaces do not allow for safe handling and control of the tool in unexpected situations.

Battery tool use and care

- ▶ **Recharge only with the charger specified by the manufacturer.** A charger that is suitable for one type of battery pack may create a risk of fire when used with another battery pack.

- ▶ **Use power tools only with specifically designated battery packs.** Use of any other battery packs may create a risk of injury and fire.
- ▶ **When battery pack is not in use, keep it away from other metal objects, like paper clips, coins, keys, nails, screws or other small metal objects, that can make a connection from one terminal to another.** Shorting the battery terminals together may cause burns or a fire.
- ▶ **Under abusive conditions, liquid may be ejected from the battery; avoid contact. If contact accidentally occurs, flush with water. If liquid contacts eyes, additionally seek medical help.** Liquid ejected from the battery may cause irritation or burns.
- ▶ **Do not use a battery pack or tool that is damaged or modified.** Damaged or modified batteries may exhibit unpredictable behaviour resulting in fire, explosion or risk of injury.
- ▶ **Do not expose a battery pack or tool to fire or excessive temperature.** Exposure to fire or temperature above 130 °C may cause explosion.
- ▶ **Follow all charging instructions and do not charge the battery pack or tool outside the temperature range specified in the instructions.** Charging improperly or at temperatures outside the specified range may damage the battery and increase the risk of fire.

Service

- ▶ **Have your power tool serviced by a qualified repair person using only identical replacement parts.** This will ensure that the safety of the power tool is maintained.
- ▶ **Never service damaged battery packs.** Service of battery packs should only be performed by the manufacturer or authorized service providers.

Safety Warnings for Mitre Saws

- ▶ **Mitre saws are intended to cut wood or wood-like products, they cannot be used with abrasive cut-off wheels for cutting ferrous material such as bars, rods, studs, etc.** Abrasive dust causes moving parts such as the lower guard to jam. Sparks from abrasive cutting will burn the lower guard, the kerf insert and other plastic parts.
- ▶ **Use clamps to support the workpiece whenever possible. If supporting the workpiece by hand, you must always keep your hand at least 100 mm from either side of the saw blade. Do not use this saw to cut pieces that are too small to be securely clamped or held by hand.** If your hand is placed too close to the saw blade, there is an increased risk of injury from blade contact.
- ▶ **The workpiece must be stationary and clamped or held against both the fence and the table. Do not feed the workpiece into the blade or cut "freehand" in any way.** Unrestrained or moving workpieces could be thrown at high speeds, causing injury.
- ▶ **Push the saw through the workpiece. Do not pull the saw through the workpiece. To make a cut, raise the saw head and pull it out over the workpiece without cutting, start the motor, press the saw head down and push the saw through the workpiece.** Cutting on the pull stroke is likely to cause the saw blade to climb on top of the workpiece and violently throw the blade assembly towards the operator.
- ▶ **Never cross your hand over the intended line of cutting either in front or behind the saw blade.** Supporting the workpiece "cross handed" i.e. holding the workpiece to the right of the saw blade with your left hand or vice versa is very dangerous.
- ▶ **Do not reach behind the fence with either hand closer than 100 mm from either side of the saw blade, to remove wood scraps, or for any other reason while the blade is spinning.** The proximity of the spinning saw blade to your hand may not be obvious and you may be seriously injured.
- ▶ **Inspect your workpiece before cutting. If the workpiece is bowed or warped, clamp it with the outside bowed face toward the fence. Always make certain that there is no gap between the workpiece, fence and table along the line of the cut.** Bent or warped workpieces can twist or shift and may cause binding on the spinning saw blade while cutting. There should be no nails or foreign objects in the workpiece.
- ▶ **Do not use the saw until the table is clear of all tools, wood scraps, etc., except for the workpiece.** Small debris or loose pieces of wood or other objects that contact the revolving blade can be thrown with high speed.
- ▶ **Cut only one workpiece at a time.** Stacked multiple workpieces cannot be adequately clamped or braced and may bind on the blade or shift during cutting.
- ▶ **Ensure the mitre saw is mounted or placed on a level, firm work surface before use.** A level and firm work surface reduces the risk of the mitre saw becoming unstable.
- ▶ **Plan your work. Every time you change the bevel or mitre angle setting, make sure the adjustable fence is set correctly to support the workpiece and will not interfere with the blade or the guarding system.** Without turning the tool "ON" and with no workpiece on the table, move the saw blade through a complete simulated cut to assure there will be no interference or danger of cutting the fence.
- ▶ **Provide adequate support such as table extensions, saw horses, etc. for a workpiece that is wider or longer than the table top.** Workpieces longer or wider than the mitre saw table can tip if not securely supported. If the cut-off piece or workpiece tips, it can lift the lower guard or be thrown by the spinning blade.
- ▶ **Do not use another person as a substitute for a table extension or as additional support.** Unstable support for the workpiece can cause the blade to bind or the workpiece to shift during the cutting operation pulling you and the helper into the spinning blade.
- ▶ **The cut-off piece must not be jammed or pressed by any means against the spinning saw blade.** If confined,

i.e. using length stops, the cut-off piece could get wedged against the blade and thrown violently.

- ▶ **Always use a clamp or a fixture designed to properly support round material such as rods or tubing.** Rods have a tendency to roll while being cut, causing the blade to "bite" and pull the work with your hand into the blade.
- ▶ **Let the blade reach full speed before contacting the workpiece.** This will reduce the risk of the workpiece being thrown.
- ▶ **If the workpiece or blade becomes jammed, turn the mitre saw off. Wait for all moving parts to stop and disconnect the plug from the power source and/or remove the battery pack. Then work to free the jammed material.** Continued sawing with a jammed workpiece could cause loss of control or damage to the mitre saw.
- ▶ **After finishing the cut, release the switch, hold the saw head down and wait for the blade to stop before removing the cut-off piece.** Reaching with your hand near the coasting blade is dangerous.
- ▶ **Hold the handle firmly when making an incomplete cut or when releasing the switch before the saw head is completely in the down position.** The braking action of the saw may cause the saw head to be suddenly pulled downward, causing a risk of injury.
- ▶ **Do not let go of the handle once the saw head has reached the lowest position. Always guide the saw head back to the top position by hand.** There is a risk of injury if the saw head moves in an uncontrolled manner.
- ▶ **Keep your work area clean.** Material mixtures are particularly hazardous. Light metal dust may catch fire or explode.
- ▶ **Do not use dull, cracked, bent or damaged saw blades. Unsharpened or improperly set saw blades produce narrow kerf causing excessive friction, blade binding and kickback.**
- ▶ **Do not use saw blades made from high speed steel (HSS).** Such saw blades can easily break.
- ▶ **Always use saw blades with correct size and shape (diamond versus round) of arbour holes.** Saw blades that do not match the mounting hardware of the saw will run off-centre, causing loss of control.
- ▶ **Never remove cuttings, wood chips, etc. from the cutting area while the power tool is running.** Always guide the tool arm back to the neutral position first and then switch the power tool off.
- ▶ **Do not touch the saw blade after working before it has cooled.** The saw blade becomes very hot while working.
- ▶ **In case of damage and improper use of the battery, vapours may be emitted. The battery can set alight or explode.** Ensure the area is well ventilated and seek medical attention should you experience any adverse effects. The vapours may irritate the respiratory system.
- ▶ **Do not modify or open the battery.** There is a risk of short-circuiting.
- ▶ **The battery can be damaged by pointed objects such as nails or screwdrivers or by force applied externally.**

An internal short circuit may occur, causing the battery to burn, smoke, explode or overheat.

- ▶ **Only use the battery in the manufacturer's products.** This is the only way in which you can protect the battery against dangerous overload.



Protect the battery against heat, e.g. against continuous intense sunlight, fire, dirt, water and moisture. There is a risk of explosion and short-circuiting.



- ▶ **The power tool is delivered with a laser warning sign (see table: "Symbols and their meaning").**
- ▶ **If the text of the laser warning label is not in your national language, stick the provided warning label in your national language over it before operating for the first time.**
- ▶ **Never make warning signs on the machine unrecognisable.**



Do not direct the laser beam at persons or animals and do not stare into the direct or reflected laser beam yourself. You could blind somebody, cause accidents or damage your eyes.

- ▶ **If laser radiation hits your eye, you must close your eyes and immediately turn your head away from the beam.**
- ▶ **Do not make any modifications to the laser equipment.** The setting options described in these operating instructions can be used safely.
- ▶ **Do not let children use the power tool unsupervised.** They could unintentionally blind themselves or other persons

Symbols

Europe

The following symbols may be important for the operation of your power tool. Please take note of these symbols and their meaning. Correctly interpreting the symbols will help you to operate the power tool more effectively and safely.

Symbols and their meaning



Laser radiation

Do not look directly into the beam
Class 2 consumer laser product
EN 50689:2021



Keep hands away from the cutting area while the power tool is running. Contact with the saw blade can lead to injuries.



Wear a dust mask.

Symbols and their meaning



Wear safety goggles.



Wear hearing protection. Exposure to noise can cause hearing loss.



Danger area! Keep hands, fingers and arms away from this area.



When transporting the power tool, hold it only at the locations indicated (recessed handles) or by the transport handle.



When sawing bevel angles, the adjustable fences must be pulled outwards or removed completely.



Take note of the dimensions of the saw blade (saw blade diameter **D**, hole diameter **d**). The hole diameter **d** must match the tool spindle without play. If it is necessary to use reducers, ensure that the dimensions of the reducer are suitable for the base blade thickness and the saw blade hole diameter, as well as the tool spindle diameter. Wherever possible, use the reducers provided with the saw blade.

The saw blade diameter **D** must match the information specified on the symbol.

See also: "Dimensions of suitable saw blades" in the "Technical Data" section.

Asia/Africa/Latin America

The following symbols may be important for the operation of your power tool. Please take note of these symbols and their meaning. Correctly interpreting the symbols will help you to operate the power tool more effectively and safely.

Symbols and their meaning

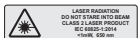

Laser radiation

Do not look directly into the beam

Laser class 2



Keep hands away from the cutting area while the power tool is running. Contact with the saw blade can lead to injuries.

Symbols and their meaning



Wear a dust mask.



Wear safety goggles.



Wear hearing protection. Exposure to noise can cause hearing loss.



Danger area! Keep hands, fingers and arms away from this area.



When transporting the power tool, hold it only at the locations indicated (recessed handles) or by the transport handle.



When sawing bevel angles, the adjustable fences must be pulled outwards or removed completely.

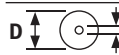

Take note of the dimensions of the saw blade (saw blade diameter **D**, hole diameter **d**). The hole diameter **d** must match the tool spindle without play. If it is necessary to use reducers, ensure that the dimensions of the reducer are suitable for the base blade thickness and the saw blade hole diameter, as well as the tool spindle diameter. Wherever possible, use the reducers provided with the saw blade.

The saw blade diameter **D** must match the information specified on the symbol.

See also: "Dimensions of suitable saw blades" in the "Technical Data" section.

Product Description and Specifications



Read all the safety and general instructions.

Failure to observe the safety and general instructions may result in electric shock, fire and/or serious injury.

Please observe the illustrations at the beginning of this operating manual.

Intended Use

The power tool is intended as a stationary machine for making straight cuts in wood with and against the grain. Mitre angles of -48° to $+48^\circ$ as well as bevel angles of 47° (left-hand side) to 47° (right-hand side) are possible.

The power tool is designed with sufficient capacity for sawing hardwood and softwood as well as chipboard and fibre-board.

When using appropriate saw blades, sawing aluminium profiles and plastic is also possible.

Europe

This product is a consumer laser product in accordance with EN 50689.

Product Features

The numbering of the product features refers to the diagram of the power tool on the graphics page.

- | | | | |
|-------------|--|-------------|---|
| (1) | Locking screw for slide device | (25) | Fixed fence |
| (2) | Slide device | (26) | Adjustable fence |
| (3) | Transport handle | (27) | Scale for bevel angle |
| (4) | Protective guard | (28) | Angle indicator for bevel angles |
| (5) | Lock-off function for on/off switch | (29) | Chip deflector |
| (6) | On/off switch | (30) | Saw blade |
| (7) | Handle | (31) | Spindle lock |
| (8) | Laser protection cap | (32) | Rechargeable battery release button |
| (9) | Laser beam outlet aperture | (33) | Rechargeable battery |
| (10) | Retracting blade guard | (34) | Transport safety lock |
| (11) | Guide roller | (35) | Tilt protector |
| (12) | Saw table | (36) | Length stop |
| (13) | Mounting holes | (37) | Dust bag |
| (14) | Insert plate | (38) | Depth stop adjusting screw |
| (15) | Locking clamp | (39) | Depth stop |
| (16) | Locking knob for various mitre angles | (40) | Threaded rod |
| (17) | Mitre pre-setting lever | (41) | Screw clamp |
| (18) | Tilt protector | (42) | Holes for screw clamp |
| (19) | Laser warning label | (43) | Hex key/slotted screwdriver |
| (20) | Detents for standard mitre angles | (44) | Locking screw for the adjustable fence |
| (21) | Scale for mitre angles | (45) | Clamping wheel for bevel angle |
| (22) | Clamping screw for saw table extension | (46) | Locking lever for bevel angle |
| (23) | Saw table extension | (47) | Opening for workpiece support (on power tool) |
| (24) | Workpiece support (flexibly pluggable) | (48) | Opening for second workpiece support (on workpiece support) |
| | | (49) | Threaded bolts |
| | | (50) | Dust extraction adapter |
| | | (51) | Hex socket screw for mounting the saw blade |
| | | (52) | Clamping flange |
| | | (53) | Inner clamping flange |
| | | (54) | Fastening screws for insert plate |
| | | (55) | Screw for laser protection cap |
| | | (56) | Fastening screw for laser housing |
| | | (57) | Laser housing |
| | | (58) | Angle indicator for mitre angles |
| | | (59) | Screw for mitre angle indicator |
| | | (60) | Screw for bevel angle indicator |
| | | (61) | Recessed handles |

Technical Data

Cordless sliding mitre saw		GCM 18V-216 D	GCM 18V-216 D
Article number		3 601 M51 0..	3 601 M51 0B. 3 601 M51 0B.
Rated voltage	V=	18	18
No-load speed ^{A)}	min ⁻¹	5000	5000
Laser type	nm	650	650

Cordless sliding mitre saw		GCM 18V-216 D	GCM 18V-216 D
	mW	< 1	< 1
Laser class		2	2
Weight ^{B)}	kg	16,6	16,6
Recommended ambient temperature during charging	°C	0 to +35	0 to +35
Permitted ambient temperature during operation ^{C)} and during storage	°C	-20 to +50	-20 to +50
Compatible rechargeable batteries		GBA18V... GBA 18V... ProCORE18V... EXPERT18V... EXBA18V... CORE18V...	
Recommended battery chargers		GAL18... GAL 18... GAL 36... GAL12V/18... GAL 12V/18... GAX 18... EXAL18...	

A) Measured at 20–25 °C with rechargeable battery **ProCORE18V 8.0Ah**

B) With screw clamp, without rechargeable battery (you can find the battery weight at www.bosch-professional.com.)

C) Limited performance at temperatures < 0 °C

Cordless sliding mitre saw		GCM 18V-216 D	GCM 18V-216 D
Article number		3 601 M51 0..	3 601 M51 0B. 3 601 M51 0B.
Dimensions of suitable saw blades			
Saw blade diameter D	mm	216	216
Base blade thickness	mm	1.2–1.8	1.2–1.8
Hole diameter d	mm	30	25.4

Permitted workpiece dimensions (maximum/minimum): (see "Permissible workpiece dimensions", page 25)

Values can vary depending on the product, scope of application and environmental conditions. To find out more, visit www.bosch-professional.com/wac.

Noise Information

Noise emission values determined according to **EN IEC 62841-3-9**.

Typically, the A-weighted noise level of the power tool is: Sound pressure level **93** dB(A); sound power level **107** dB(A). Uncertainty K = **3** dB.

Wear hearing protection!

The noise emission value given in these instructions has been measured in accordance with a standardised measuring procedure and may be used to compare power tools. It may also be used for a preliminary estimation of noise emissions.

The noise emission value given represents the main applications of the power tool. However, if the power tool is used for other applications, with different application tools or is poorly maintained, the noise emission value may differ. This may significantly increase noise emissions over the total working period.

To estimate noise emissions accurately, the times when the tool is switched off, or when it is running but not actually being used, should also be taken into account. This may significantly reduce noise emissions over the total working period.

Rechargeable battery

Bosch sells some cordless power tools without a rechargeable battery. You can tell whether a rechargeable battery is included with the power tool by looking at the packaging.

Charging the battery

► **Use only the chargers listed in the technical data.** Only these chargers are matched to the lithium-ion battery of your power tool.

Note: Lithium-ion rechargeable batteries are supplied partially charged according to international transport regula-

tions. To ensure full rechargeable battery capacity, fully charge the rechargeable battery before using your tool for the first time.

Inserting the Battery

Push the charged battery into the battery holder until it clicks into place.



Removing the Battery

To remove the rechargeable battery, press the battery release button and pull the battery out. **Do not use force to do this.**

The rechargeable battery has two locking levels to prevent the battery from falling out if the battery release button is pressed unintentionally. The rechargeable battery is held in place by a spring when fitted in the power tool.

Battery charge indicator

Note: Not all battery types have a battery charge indicator. The green LEDs on the battery charge indicator indicate the state of charge of the battery. For safety reasons, it is only possible to check the state of charge when the power tool is not in operation.

Press the button for the battery charge indicator  or  to show the state of charge. This is also possible when the battery is removed.

If no LED lights up after pressing the button for the battery charge indicator, then the battery is defective and must be replaced.

Rechargeable battery type GBA 18V... | GBA18V...



LED	Capacity
3 × continuous green light	60–100 %
2 × continuous green light	30–60 %
1 × continuous green light	5–30 %
1 × flashing green light	0–5 %

Battery model ProCORE18V... | EXPERT18V... | EXBA18V... | CORE18V...





LED	Capacity
5 × continuous green light	80–100 %
4 × continuous green light	60–80 %
3 × continuous green light	40–60 %
2 × continuous green light	20–40 %
1 × continuous green light	5–20 %
1 × flashing green light	0–5 %

Battery defect risk detection

EXPERT18V... | EXBA18V...

In addition to the state of charge of the rechargeable battery, the LEDs on the battery charge indicator can also indicate the risk of a battery defect.

To activate the function, press and hold the button for the battery charge indicator  for 3 seconds. The analysis of the battery is signalled by a moving light on the battery charge indicator. The result of is shown on the battery charge indicator.

 **1 LED:** The rechargeable battery has a high defect risk. Performance and runtime may already be reduced. Replacing the rechargeable battery is recommended.

 **5 LEDs:** The rechargeable battery is in good condition and has a low defect risk.

Please note: The rechargeable battery defect risk assessment works in a binary manner and offers a simplified status assessment, indicating either that the rechargeable battery is in good condition or that the rechargeable battery has an increased defect risk. A percentage of the battery status is not shown.

Recommendations for Optimal Handling of the Battery

Protect the battery against moisture and water.

Only store the battery within a temperature range of -20 to 50 °C. Do not leave the battery in your car in the summer, for example.

Occasionally clean the ventilation slots on the battery using a soft brush that is clean and dry.

A significantly reduced operating time after charging indicates that the battery has deteriorated and must be replaced. Follow the instructions on correct disposal.

Assembly

► **Before carrying out any work on the power tool (e.g. maintenance, tool change etc.), remove the battery from the power tool.** There is risk of injury from unintentionally pressing the on/off switch.

Items included



See the list of items included at the start of the operating manual.

Check to ensure that all the parts listed below have been supplied before using the power tool for the first time:

- Sliding mitre saw with fitted saw blade
- Clamping wheel **(45)**
- Adjustable fence **(26)**
- Screw clamp **(41)**
- Hex key/slotted screwdriver **(43)**
- Dust bag **(37)**

- Workpiece supports **(24)** (2 pieces)

Note: Check the power tool for possible damage.

Before continuing to use the power tool, carefully check that all protective devices or slightly damaged parts are working perfectly and according to specifications. Check that the moving parts are working perfectly and without jamming; check whether any parts are damaged. All parts must be fitted correctly and all the conditions necessary to ensure smooth operation must be met.

If the protective devices or any parts become damaged, you must have them properly repaired or replaced by an authorised service centre.

Fitting individual components

- Carefully remove all parts included in the delivery from their packaging.
- Remove all packing material from the power tool and the accessories provided.
- For ease of assembly when fitting the tool elements that are provided, be aware that the power tool is supplied in the transport position.

Installing Workpiece Supports (see figure A1)

The workpiece supports **(24)** can be positioned left, right or in front of the power tool. The flexible connector system enables a multitude of extension or expansion variants (see figure G).

- Insert the workpiece support **(24)** into the openings **(47)** on the power tool or into the openings **(48)** of the second workpiece support as required.
- ▶ **Never carry the power tool using the workpiece supports. Only use the transport devices to transport the power tool.**

Fitting the Clamping Wheel (see figure A2)

The clamping wheel **(45)** fixes the selected bevel angle and is required for safe operation.

- Unscrew the hex nut from the threaded bolts **(49)**.
- Screw the clamping wheel **(45)** clockwise onto the threaded bolts **(49)** and tighten it.

Fitting the Adjustable Fence (see figure A3)

The adjustable fence **(26)** must be fitted before sawing.

- Slide the fence **(26)** on the right of the saw blade into the corresponding groove and tighten the locking screw **(44)**. The levelled side of the fence must face inwards towards the saw blade.

Stationary or flexible mounting

- ▶ **To ensure safe handling, the power tool must be mounted on a flat, stable work surface (e.g. work bench) before use.**

Mounting on a work surface (see figure B1–B2)

- Use suitable screw fasteners to secure the power tool to the work surface. The holes **(13)** are used for this purpose.

or

- Firmly clamp the base of the power tool to the work surface with commercially available screw clamps.

Mounting on a Bosch saw stand

With the height-adjustable legs, Bosch GTA saw stands provide firm support for the power tool on any surface. The workpiece supports of the saw stand are used for underlaying long workpieces.

- ▶ **Read all the warnings and instructions included with the saw stand.** Failure to observe the warnings and follow instructions may result in electric shock, fire and/or serious injury.

- ▶ **Assemble the saw stand properly before mounting the power tool.** Correct assembly is important to prevent the risk of collapsing.

- Mount the power tool on the saw stand in the transport position.

Flexible installation (not recommended) (see figure B3)

If, in exceptional circumstances, it is not possible to mount the power tool on a flat and stable work surface, you can improvise by setting it up with the tilt protector.

- ▶ **Without the tilt protector, the power tool will not be stable and can tip over especially when sawing maximum mitre and/or bevel angles.**
- Rotate the tilt protector **(18)** inwards or outwards until the power tool is positioned straight on the work surface.

Dust/Chip Extraction

Do not perform work without taking dust-reducing measures.

Using a suitable dust extraction attachment or a dust box/dust bag will reduce exposure to harmful dust. Provide good ventilation at the workplace. Always use suitable breathing protection. If you are using a dust box, empty it in good time and clean the filter element regularly to ensure optimal dust extraction.

If you are using a dust extractor, refer to the requirements listed below. The regulations on the material being machined that apply in the country of use must be observed.

- ▶ **Avoid dust accumulation at the workplace.** Dust can easily ignite.

Requirements for the Dust Extractor		
Recommended hose nominal diameter	mm	28
Required vacuum pressure ^{A)}	mbar hPa	≥ 140 ≥ 140
Required flow rate ^{A)}	l/s m ³ /h	≥ 23 ≥ 82.8
Recommended filter efficiency	Dust class M ^{B)}	

A) Power value at the power tool's dust extractor connection

B) According to IEC/EN 60335-2-69

Refer to the dust extractor's instructions. If there is reduced suction power, stop working and eliminate the cause.

The dust/chip extraction system can be blocked by dust, chips or fragments of the workpiece.

- Switch the power tool off and remove the battery.
- Wait until the saw blade has come to a complete stop.
- Determine the cause of the blockage and eliminate it.

Self-generated dust extraction (see figure C)

For basic chip collection, use the dust bag (37) provided.

- Turn the transport handle (3) so that it is vertical.
- Place the dust bag (37) onto the extraction adapter (50) and turn so that the pin of the dust bag locks in place in the recess of the extraction adapter.

During sawing, the dust bag must not come into contact with moving tool components.

Always empty the dust bag in good time.

- ▶ **Check and clean the dust bag each time after using.**
- ▶ **When sawing aluminium, remove the dust bag to avoid the risk of fire.**

External Dust Extraction

You can also attach a dust extraction hose (35 mm diameter) to the extraction adapter (50) for extraction.

- Connect the dust extraction hose to the extraction adapter (50).

The dust extractor must be suitable for the material being worked.

When extracting dry dust that is especially detrimental to health or carcinogenic, use a special dust extractor.

Changing the saw blade (see figures D1–D4)

- ▶ **Wear protective gloves when fitting the saw blade.**

There is a risk of injury when touching the saw blade.

Only use saw blades that have a maximum permitted speed higher than the no-load speed of the power tool.

Only use saw blades that match the specifications given in this operating manual and that have been tested and marked in accordance with EN 847-1.

Only use saw blades that are recommended by the power tool manufacturer and are suitable for use on the material you want to saw. This will prevent the saw teeth overheating when sawing.

Removing the Saw Blade

- Bring the power tool into the work position.
- Swivel the retracting blade guard (10) to the back and hold it in this position.
- Turn the hex socket screw (51) with the hex key (6 mm) (43) and at the same time push the spindle lock (31) until it engages.
- Keep holding the spindle lock (31) and loosen the hex socket screw (51) by turning it clockwise (left-hand thread).
- Remove the clamping flange (52).
- Remove the saw blade (30).
- Slowly push the retracting blade guard back down.

Fitting the saw blade

- ▶ **When fitting the saw blade, make sure that the cutting direction of the teeth (arrow direction on the saw blade) matches the direction of the arrow on the protective guard.**

If required, clean all the parts you want to fit before installing them.

- Swivel the retracting blade guard (10) to the back and hold it in this position.
- Place the new saw blade on the inner clamping flange (53).
- Fit the clamping flange (52) and the hex socket screw (51). Press the spindle lock (31) until it engages and tighten the hex socket screw by turning it anticlockwise.
- Slowly push the retracting blade guard back down.

Operation

- ▶ **Before carrying out any work on the power tool (e.g. maintenance, tool change etc.), remove the battery from the power tool.** There is risk of injury from unintentionally pressing the on/off switch.

Transport Safety Lock (see figure E)

The transport safety lock (34) makes it easier to handle the power tool when transporting it to various working locations.

Unlocking the power tool (work position)

- Press the tool arm down slightly by the handle (7) to release the transport safety lock (34).
- Pull the transport safety lock (34) all the way out.
- Slowly guide the tool arm upwards.

Locking the power tool (transport position)

- Loosen the locking screw (1) if it is clamping the slide device (2) in place. Pull the tool arm fully forward and tighten the locking screw again to lock the slide device.
- Pull the depth stop (39) upwards.
- To lock the saw table (12) in place, tighten the locking knob (16).
- Swing the tool arm downwards by the handle (7) until you can press the transport safety lock (34) all the way in.

The tool arm is now securely locked and ready for transportation.

Preparing for operation

To ensure precise cuts, the basic settings of the power tool must be checked and adjusted as necessary after intensive use.

Experience and suitable special tools are required for this. A Bosch after-sales service point will handle this work quickly and reliably.

Extending/Expanding the Saw Table (see figures F–G)

The free end of long and heavy workpieces must have something placed underneath it or be supported.

The saw table can be extended left and right using the saw table extensions (23).

- Loosen the clamping screw (22).
- Pull out the saw table extension (23) to the required length.
- Retighten the clamping screw (22) to fix the saw table extension.

Moving the fence (see figure H)

When sawing mitre and/or bevel angles, you have to pull the left-hand or right-hand adjustable fence (26) outwards depending on the cutting direction, or remove it completely.

Bevel angle	Mitre angle	
0°–22.5° (left/right)	> 0°	<ul style="list-style-type: none"> – Loosen the left-hand/right-hand locking screw (44). – Pull the left-hand/right-hand adjustable fence (26) all the way out.
22.5°–47° (left/right)	≤ 48° (left/right)	<ul style="list-style-type: none"> – Loosen the left-hand/right-hand locking screw (44). – Pull the left-hand/right-hand adjustable fence (26) all the way out. – Lift the adjustable fence upwards and out of the way.

Clamping the Workpiece (see figure I)

To ensure maximum safety while working, the workpiece must always be firmly clamped.

Do not saw workpieces that are too small to clamp firmly.

- Press the workpiece firmly against the fences (26) and (25).
- Insert the supplied screw clamp (41) into one of the corresponding holes (42).
- Adjust the threaded rod (40) of the screw clamp to the workpiece height.
- Tighten the threaded rod (40) to fix the workpiece in place.

Adjusting mitre angles

Setting Standard Mitre Angles (see figure J)

For quick and precise setting of commonly used mitre angles, detents (20) are provided on the saw table:

Left	Right
0°	
45°; 30°; 22.5°; 15°	15°; 22.5°; 30°; 45°

- Loosen the locking knob (16) if it is tightened.
- Pull the lever (17) and rotate the saw table (12) left or right to the required detent.
- Release the lever again. The lever must be felt to engage in the detent.
- Retighten the locking knob (16).

Setting Any Mitre Angle (see figure K)

The mitre angle can be set between 48° (left-hand side) and 48° (right-hand side).

- Loosen the locking knob (16) if it is tightened.

The flexible connector system of the workpiece supports (24) enables a multitude of extension or expansion variants.

- Insert the workpiece support (24) into the openings (47) on the power tool or into the openings (48) of the second workpiece support as required.

► **Never carry the power tool using the workpiece supports.**
Only use the transport devices to transport the power tool.

- Pull the lever (17) and at the same time press the locking clamp (15) until this clicks into the slot provided for it. This means the saw table can now move freely.
- Turn the saw table (12) left or right by the locking knob until the angle indicator (58) shows the required mitre angle.
- Retighten the locking knob (16).
- To loosen the lever (17) again (for setting standard mitre angles), pull the lever upwards. The locking clamp (15) springs back into its original position and the lever (17) can click back into the detents (20).

Adjusting bevel angles

The bevel angle can be set between 47° (left-hand side) and 47° (right-hand side).

For quick and precise setting of frequently used bevel angles, fixed positions have been provided for the angles 0°, 22.5° and 45°.

- Make sure that the clamping wheel (45) is fitted (see "Fitting the Clamping Wheel (see figure A2)", page 21).

Setting Standard Bevel Angles (see figure L)

- Pull the adjustable fences (26) all the way out or remove them completely.
- Release the clamping wheel (45).
- Pull the locking lever (46) out and engage it in the free running position. This enables you to use the complete bevel angle range (left and right).
- Swivel the tool arm left or right by the handle (7) until the angle indicator (28) shows the required standard bevel angle.

- Turn the locking lever **(46)**. The locking lever must be felt to engage in the position of the required standard bevel angle.
- Retighten the clamping wheel **(45)**.

Setting any bevel angle

- Pull the adjustable fences **(26)** all the way out or remove them completely.
- Release the clamping wheel **(45)**.
- Pull the locking lever **(46)** out and engage it in the free running position.
This enables you to use the complete bevel angle range (left and right).
- Swivel the tool arm left or right by the handle **(7)** until the angle indicator **(28)** shows the required bevel angle.
- Retighten the clamping wheel **(45)**.

Start-up

- ▶ **Always tighten the locking knob (16) and the clamping wheel (45) firmly before sawing.** Otherwise the saw blade can become wedged in the workpiece.

Switching on (see figure M)

- To **switch on** the power tool, **first** slide the lock-off button **(5)** to the middle and **then** press and hold the on/off switch **(6)**.

Note: For safety reasons, the on/off switch **(6)** cannot be locked; it must remain pressed during the entire operation.

Switching off

- To **switch off**, release the on/off switch **(6)**.

Sawing

General sawing instructions

- ▶ **Always tighten the locking knob (16) and the clamping wheel (45) firmly before sawing.** Otherwise the saw blade can become wedged in the workpiece.
- ▶ **For all cuts, it must first be ensured that the saw blade at no time can come in contact with the fence, screw clamps or other machine parts. Remove any mounted auxiliary stops or adjust them accordingly.**

Protect the saw blade against impact and shock. Do not subject the saw blade to lateral pressure.

Only saw materials which are permitted within the scope of the intended use.

Do not saw warped/bent workpieces. The workpiece must always have a straight edge to face against the fence.

The free end of long and heavy workpieces must have something placed underneath it or be supported.

Make sure that the retracting blade guard operates properly and that it can move freely. The retracting blade guard must open when the tool arm is guided downwards. When the tool arm is guided upwards, the retracting blade guard must close again over the saw blade and lock in the uppermost position of the tool arm.

Position of the operator (see figure N)

- ▶ **Do not stand in line with the saw blade in front of the power tool. Always stand to the side of the saw blade.**
This protects your body against possible kickback.
- Keep hands, fingers and arms away from the rotating saw blade.
- Do not reach one hand across the other when in front of the tool arm.

Sawing with slide movement

- For cuts made using the slide device **(2)** (wide workpieces), loosen the locking screw **(1)** if it is tightened.
- Set the required mitre and/or bevel angle as necessary.
- Press the workpiece firmly against the fences **(25)** and **(26)**.
- Firmly clamp the workpiece as appropriate for its dimensions.
- Pull the tool arm away from the fence **(25)** until the saw blade is in front of the workpiece.
- Switch the power tool on.
- Slowly guide the tool arm downwards using the handle **(7)**.
- Now push the tool arm towards the fences **(25)** and **(26)** and saw through the workpiece with uniform feed.
- Switch off the power tool and wait until the saw blade has come to a complete stop.
- Slowly guide the tool arm upwards.

Sawing without slide movement (cutting off) (see figure O)

- For cuts without slide movement (small workpieces), loosen the locking screw **(1)** if it is tightened. Push the tool arm all the way towards the fence **(25)** and retighten the locking screw **(1)**.
- Set the required mitre and/or bevel angle as necessary.
- Press the workpiece firmly against the fences **(25)** and **(26)**.
- Firmly clamp the workpiece as appropriate for its dimensions.
- Switch the power tool on.
- Slowly guide the tool arm downwards using the handle **(7)**.
- Saw through the workpiece applying uniform feed.
- Switch off the power tool and wait until the saw blade has come to a complete stop.
- Slowly guide the tool arm upwards.

Practical advice

Marking the Cutting Line (see figure P)

Two laser beams indicate the cutting line of the saw blade. This allows for exact positioning of the workpiece for sawing, without having to open the retracting blade guard.

- To do this, switch on the laser beams by briefly pressing the on/off switch **(6)** without pressing the lock-off button **(5)**.

- Position your mark on the workpiece between the two laser lines.

Note: Before sawing, check if the cutting line is still indicated correctly (see "Adjusting the laser", page 25). Vibrations during intensive use, for example, can cause the laser beams to become misaligned.

Permissible workpiece dimensions

Maximum workpiece dimensions:

Mitre angle	Bevel angle	Height x width [mm]
0°	0°	70 x 305
45° (left/right)	0°	70 x 215
45° (left)	45° (left)	42 x 215
45° (right)	45° (right)	20 x 215
0°	45° (left)	42 x 305
0°	45° (right)	20 x 305

Minimum workpiece dimensions (= all workpieces that can be secured left or right of the saw blade using the supplied screw clamps **(41)**): 100 x 40 mm (length x width)

Maximum cutting depth (0°/0°): 70 mm

Adjusting the Depth Stop (Sawing the Groove) (see figure Q)

The depth stop needs to be adjusted if you wish to saw a groove.

- Swivel the depth stop **(39)** forwards.
- Swivel the tool arm by the handle **(7)** into the required position.
- Turn the adjusting screw **(38)** until the end of the screw touches the depth stop **(39)**.
- Slowly guide the tool arm upwards.

Sawing workpieces of the same length (see figure R)

The left or right length stop **(36)** can be used for easily sawing workpieces of the same length.

- Turn the length stop **(36)** upwards.
- Set the saw table extension **(23)** to the required workpiece length.

Special workpieces

When sawing curved or round workpieces, these must be especially secured against slipping. At the cutting line, there should be no gap between the workpiece, fence and saw table.

If necessary, you will need to manufacture special fixtures.

Replacing insert plates (see figure S)

The insert plates **(14)** can become worn after prolonged use of the power tool.

Replace faulty insert plates.

- Bring the power tool into the work position.
- Unscrew the screws **(54)** using a commercially available cross-headed screwdriver and remove the old insert plate **(14)**.

- Insert the new insert plate and screw the screws **(54)** in tight again.

Adjusting the laser

Note: To test the laser function, the power tool must be connected to the power supply.

► **While adjusting the laser (e.g. when moving the tool arm), never activate the on/off switch.** Starting the power tool accidentally can lead to injuries.

- Bring the power tool into the work position.
- Turn the saw table **(12)** to the 0° detent **(20)**. The lever **(17)** must be felt to engage in the detent.

To ensure precise cuts, the laser beams must be checked and adjusted as necessary after intensive use.

Experience and suitable special tools are required for this. A Bosch after-sales service point will handle this work quickly and reliably.

Checking (see figure T1)

- Draw a straight cutting line on the workpiece.
- Slowly guide the tool arm downwards using the handle **(7)**.
- Position the workpiece so that the teeth of the saw blade line up with the cutting line.
- Hold the workpiece in this position and slowly guide the tool arm back up.
- Clamp the workpiece.
- Turn on the laser beams using the switch **(6)** without pressing the lock-off button **(5)**.

The laser beams must be at the same distance from the marked cutting line on the workpiece left and right along the entire length, even if the tool arm is being guided downwards.

Removing the Laser Protection Cap (see figure T2)

- Unscrew the two screws **(55)** of the laser protection cap **(8)** using a hex key/slotted screwdriver **(43)** and remove the laser protection cap.

Adjusting the Lateral Deviation when Moving the Tool Arm (see figures T3–T4)

- Loosen the fastening screw **(56)** (by approx. one to two turns).
Do not unscrew the screw completely.
- Move the laser housing **(57)** right or left until the laser beams no longer laterally deviate when the tool arm moves downwards.
- Hold the laser housing **(57)** in this position and retighten the fastening screw **(56)**.
- Reattach the laser protection cap **(8)**.

Checking and Adjusting the Basic Settings

To ensure precise cuts, the basic settings of the power tool must be checked and adjusted as necessary after intensive use.

Experience and suitable special tools are required for this.

A Bosch after-sales service point will handle this work quickly and reliably.

Aligning the mitre angle indicator (see figure U)

- Bring the power tool into the work position.
- Turn the saw table (12) to the 0° detent (20). The lever (17) must be felt to engage in the detent.

Checking

The angle indicator (58) must be in line with the 0° mark of the scale (21).

Setting

- Loosen the screw (59) using a cross-headed screwdriver and align the angle indicator along the 0° mark.
- Retighten the screw.

Aligning the Angle Indicator (Vertical) (see figure V)

- Bring the power tool into the work position.
- Release the clamping wheel (45).
- Pull the locking lever (46) out and set the bevel angle to 0° with the tool arm.
- Let go of the locking lever (46). The locking lever must be felt to engage in the position
- Retighten the clamping wheel (45).

Checking

The angle indicator (28) must be in line with the 0° mark of the scale (27).

Setting

- Loosen the screw (60) using a cross-headed screwdriver and align the angle indicator along the 0° mark.
- Retighten the screw.

Transporting the Power Tool (see figure W)

- ▶ **Before carrying out any work on the power tool (e.g. maintenance, tool change etc.), remove the battery from the power tool.** There is risk of injury from unintentionally pressing the on/off switch.

Before transporting the power tool, the following steps must be carried out:

- Loosen the locking screw (1) if it is tightened. Pull the tool arm fully forwards and retighten the locking screw.
- Ensure that the depth stop (39) is swung all the way back and the adjusting screw (38) does not touch anything when you move the tool arm.
- Bring the power tool into the transport position.
- Remove all accessories that cannot be securely fitted to the power tool. If possible, transport unused saw blades in an enclosed container.
- Turn the transport handle (3) so that it is vertical.
- Carry the power tool by the transport handle (3) or hold it by the recessed handles (61) on the sides of the saw table.

- ▶ **Only use the transport devices to transport the power tool and never the protective devices or workpiece supports.**

Maintenance and Service

Maintenance and Cleaning

- ▶ **Before carrying out any work on the power tool (e.g. maintenance, tool change etc.), remove the battery from the power tool.** There is risk of injury from unintentionally pressing the on/off switch.
- ▶ **To ensure safe and efficient operation, always keep the power tool and the ventilation slots clean.**

The retracting blade guard (10) must always be able to move freely and retract automatically. It is therefore important to keep the area around the retracting blade guard clean at all times.

Always remove dust and chips after working by blowing out with compressed air or using a brush.

Clean the guide roller (11) regularly.

Noise reduction measures

Measures implemented by the manufacturer:

- Soft start
- Provided with a saw blade specially developed for noise reduction

Measures implemented by the operator:

- Low-vibration mounting on a stable work surface
- Use of saw blades with noise-reducing functions
- Regular cleaning of the saw blade and power tool

After-Sales Service and Application Service

Australia

Phone: (01300) 307044

Great Britain

Tel. Service: (0344) 7360109

GB Importer:

Robert Bosch Ltd.
Broadwater Park
North Orbital Road
Uxbridge
UB9 5HJ

India

Phone: (044) 64561816

Israel

Tel. 03-9630050

Korea

Tel.: 080-955-0909 (Hotline)

Malaysia

Tel.: (03) 79663194

In all correspondence and spare parts orders, please always include the 10-digit article number given on the nameplate of the product.

Transport

The recommended lithium-ion batteries are subject to legislation on the transport of dangerous goods. The user can

transport the batteries by road without further requirements.

When the batteries are shipped by third parties (e.g. air transport or forwarding agency), special requirements on packaging and labelling (e.g. ADR regulations) must be met. A dangerous goods expert must be consulted when preparing the items for shipping.

Dispatch battery packs only when the housing is undamaged. Tape or mask off open contacts and pack up the battery in such a manner that it cannot move around in the packaging. Please also observe the possibility of more detailed national regulations.

Disposal

Power tools, rechargeable batteries, accessories and packaging should be sorted for environmental-friendly recycling.



Do not dispose of power tools and batteries/rechargeable batteries into household waste!

Only for EU countries and United Kingdom:

Electrical and electronic equipment or used batteries that are no longer suitable for use must be collected separately and disposed of in an environmentally friendly manner. Use the designated collection systems. Incorrect disposal may cause harmful effects on the environment and human health, due to the potential presence of hazardous substances.



1 609 B07 930



1 609 B06 930



1 609 B07 675



GTA 3800
0 601 B24 000



GTA 2500 Compact
0 601 B12 400



GTA 2600
0 601 B12 300



GTA 2500 W
0 601 B12 100

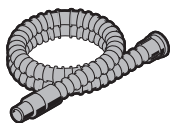

Ø 28 mm:
2 608 000 772 (3.2 m)



GAS 18V-12 MC

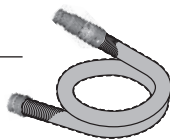
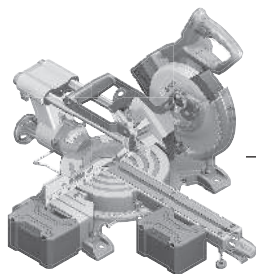

Ø 28 mm:
2 608 000 885 (4 m)



GAS 12-40 MA

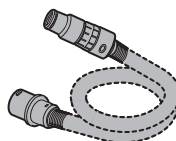

Ø 22 mm:
2 608 000 567 (5 m)
Ø 35 mm:
2 608 000 565 (5 m)



GAS 35 M AFC



GAS 55 M AFC



Ø 22 mm:
2 608 000 568 (5 m)
Ø 35 mm:
2 608 000 566 (5 m)

Legal Information and Licenses

Copyright © 2011 Petteri Aimonen

This software is provided 'as-is', without any express or implied warranty. In no event will the authors be held liable for any damages arising from the use of this software.

Permission is granted to anyone to use this software for any purpose, including commercial applications, and to alter it and redistribute it freely, subject to the following restrictions:

1. The origin of this software must not be misrepresented; you must not claim that you wrote the original software. If you use this software in a product, an acknowledgment in the product documentation would be appreciated but is not required.
2. Altered source versions must be plainly marked as such, and must not be misrepresented as being the original software.
3. This notice may not be removed or altered from any source distribution.

Copyright © 2010–2013 ARM LIMITED

All rights reserved.

Redistribution and use in source and binary forms, with or without modification, are permitted provided that the following conditions are met:

- Redistributions of source code must retain the above copyright notice, this list of conditions and the following disclaimer.
- Redistributions in binary form must reproduce the above copyright notice, this list of conditions and the following disclaimer in the documentation and/or other materials provided with the distribution.
- Neither the name of ARM nor the names of its contributors may be used to endorse or promote products derived from this software without specific prior written permission.

THIS SOFTWARE IS PROVIDED BY THE COPYRIGHT HOLDERS AND CONTRIBUTORS "AS IS" AND ANY EXPRESS OR IMPLIED WARRANTIES, INCLUDING, BUT NOT LIMITED TO, THE IMPLIED WARRANTIES OF MERCHANTABILITY AND FITNESS FOR A PARTICULAR PURPOSE ARE DISCLAIMED. IN NO EVENT SHALL THE COPYRIGHT HOLDERS AND CONTRIBUTORS BE LIABLE FOR ANY DIRECT, INDIRECT, INCIDENTAL, SPECIAL, EXEMPLARY, OR CONSEQUENTIAL DAMAGES (INCLUDING, BUT NOT LIMITED TO, PROCUREMENT OF SUBSTITUTE GOODS OR SERVICES; LOSS OF USE, DATA, OR PROFITS; OR BUSINESS INTERRUPTION) HOWEVER CAUSED AND ON ANY THEORY OF LIABILITY, WHETHER IN CONTRACT, STRICT LIABILITY, OR TORT (INCLUDING NEGLIGENCE OR OTHERWISE) ARISING IN ANY WAY OUT OF THE USE OF THIS SOFTWARE, EVEN IF ADVISED OF THE POSSIBILITY OF SUCH DAMAGE.

Copyright © 2014 STMicroelectronics

Under STMicroelectronics' intellectual property rights, the redistribution, reproduction and use in source and binary forms of the software or any part thereof, with or without modification, are permitted provided that the following conditions are met:

1. Redistribution of source code (modified or not) must retain any copyright notice, this list of conditions and the disclaimer set forth below as items 10 and 11.
2. Redistributions in binary form, except as embedded into microcontroller or microprocessor device manufactured by or for STMicroelectronics or a software update for such device, must reproduce any copyright notice provided with the binary code, this list of conditions, and the disclaimer set forth below as items 10 and 11, in documentation and/or other materials provided with the distribution.

3. Neither the name of STMicroelectronics nor the names of other contributors to this software may be used to endorse or promote products derived from this software or part thereof without specific written permission.

4. This software or any part thereof, including modifications and/or derivative works of this software, must be used and execute solely and exclusively on or in combination with a microcontroller or microprocessor device manufactured by or for STMicroelectronics.

5. No use, reproduction or redistribution of this software partially or totally may be done in any manner that would subject this software to any Open Source Terms. "Open Source Terms" shall mean any open source license which requires as part of distribution of software that the source code of such software is distributed therewith or otherwise made available, or open source license that substantially complies with the Open Source definition specified at www.opensource.org and any other comparable open source license such as for example GNU General Public License (GPL), Eclipse Public License (EPL), Apache Software License, BSD license or MIT license.

6. STMicroelectronics has no obligation to provide any maintenance, support or updates for the software.

7. The software is and will remain the exclusive property of STMicroelectronics and its licensors. The recipient will not take any action that jeopardizes STMicroelectronics and its licensors' proprietary rights or acquire any rights in the software, except the limited rights specified hereunder.

8. The recipient shall comply with all applicable laws and regulations affecting the use of the software or any part thereof including any applicable export control law or regulation.

9. Redistribution and use of this software or any part thereof other than as permitted under this license is void and will automatically terminate your rights under this license.

10. THIS SOFTWARE IS PROVIDED BY STMICROELECTRONICS AND CONTRIBUTORS "AS IS" AND ANY EXPRESS, IMPLIED OR STATUTORY WARRANTIES, INCLUDING, BUT NOT LIMITED TO, THE IMPLIED WARRANTIES OF MERCHANTABILITY, FITNESS FOR A PARTICULAR PURPOSE AND NON-INFRINGEMENT OF THIRD PARTY INTELLECTUAL PROPERTY RIGHTS, WHICH ARE DISCLAIMED TO THE FULLEST EXTENT PERMITTED BY LAW. IN NO EVENT SHALL STMICROELECTRONICS OR CONTRIBUTORS BE LIABLE FOR ANY DIRECT, INDIRECT, INCIDENTAL, SPECIAL, EXEMPLARY, OR CONSEQUENTIAL DAMAGES (INCLUDING, BUT NOT LIMITED TO, PROCUREMENT OF SUBSTITUTE GOODS OR SERVICES; LOSS OF USE, DATA, OR PROFITS; OR BUSINESS INTERRUPTION) HOWEVER CAUSED AND ON ANY THEORY OF LIABILITY, WHETHER IN CONTRACT, STRICT LIABILITY, OR TORT (INCLUDING NEGLIGENCE OR OTHERWISE) ARISING IN ANY WAY OUT OF THE USE OF THIS SOFTWARE, EVEN IF ADVISED OF THE POSSIBILITY OF SUCH DAMAGE.

11. EXCEPT AS EXPRESSLY PERMITTED HEREUNDER, NO LICENSE OR OTHER RIGHTS, WHETHER EXPRESS OR IMPLIED, ARE GRANTED UNDER ANY PATENT OR OTHER INTELLECTUAL PROPERTY RIGHTS OF STMICROELECTRONICS OR ANY THIRD PARTY.

Apache 2.0 License

Copyright © 2009-2020 Arm Limited. All rights reserved.

Version 2.0, January 2004

<http://www.apache.org/licenses/>

TERMS AND CONDITIONS FOR USE, REPRODUCTION, AND DISTRIBUTION

1. Definitions.

"License" shall mean the terms and conditions for use, reproduction, and distribution as defined by Sections 1 through 9 of this document.

"Licensor" shall mean the copyright owner or entity authorized by the copyright owner that is granting the License.

"Legal Entity" shall mean the union of the acting entity and all other entities that control, are controlled by, or are under common control with that entity. For the purposes of this definition, **"control"** means (i) the power, direct or indirect, to cause the direction or management of such entity, whether by contract or otherwise, or (ii) ownership of fifty percent (50%) or more of the outstanding shares, or (iii) beneficial ownership of such entity.

"You" (or **"Your"**) shall mean an individual or Legal Entity exercising permissions granted by this License.

"Source" form shall mean the preferred form for making modifications, including but not limited to software source code, documentation source, and configuration files.

"Object" form shall mean any form resulting from mechanical transformation or translation of a Source form, including but not limited to compiled object code, generated documentation, and conversions to other media types.

"Work" shall mean the work of authorship, whether in Source or Object form, made available under the License, as indicated by a copyright notice that is included in or attached to the work (an example is provided in the Appendix below).

"Derivative Works" shall mean any work, whether in Source or Object form, that is based on (or derived from) the Work and for which the editorial revisions, annotations, elaborations, or other modifications represent, as a whole, an original work of authorship. For the purposes of this License, Derivative Works shall not include works that remain separable from, or merely link (or bind by name) to the interfaces of, the Work and Derivative Works thereof.

"Contribution" shall mean any work of authorship, including the original version of the Work and any modifications or additions to that Work or Derivative Works thereof, that is intentionally submitted to Licensor for inclusion in the Work by the copyright owner or by an individual or Legal Entity authorized to submit on behalf of the copyright owner. For the purposes of this definition, **"submitted"** means any form of electronic, verbal, or written communication sent to the Licensor or its representatives, including but not limited to communication on electronic mailing lists, source code control systems, and issue tracking systems that are managed by, or on behalf of, the Licensor for the purpose of discussing and improving the Work, but excluding communication that is conspicuously marked or otherwise designated in writing by the copyright owner as **"Not a Contribution."**

"Contributor" shall mean Licensor and any individual or Legal Entity on behalf of whom a Contribution has been received by Licensor and subsequently incorporated within the Work.

2. Grant of Copyright License. Subject to the terms and conditions of this License, each Contributor hereby grants to You a perpetual, worldwide, non-exclusive, no-charge, royalty-free, irrevocable copyright license to reproduce, prepare Derivative Works of, publicly display, publicly perform, sublicense, and distribute the Work and such Derivative Works in Source or Object form.

3. Grant of Patent License. Subject to the terms and conditions of this License, each Contributor hereby grants to You a perpetual, worldwide, non-exclusive, no-charge, royalty-free, irrevocable (except as stated in this section) patent license to make, have made, use, offer to sell, sell, import, and otherwise transfer the Work, where such license applies only to those patent claims licensable by such Contributor that are necessarily infringed by their Contribution(s) alone or by combination of their Contribution(s) with the Work to which such Contribution(s) was submitted. If You institute patent litigation against any entity (including a cross-claim or counterclaim in a lawsuit) alleging that the Work or a Contribution incorporated within the Work constitutes direct or contributory patent infringement, then any patent licenses granted to You under this License for that Work shall terminate as of the date such litigation is filed.

4. Redistribution. You may reproduce and distribute copies of the Work or Derivative Works thereof in any medium, with or without

modifications, and in Source or Object form, provided that You meet the following conditions:

- You must give any other recipients of the Work or Derivative Works a copy of this License; and
- You must cause any modified files to carry prominent notices stating that You changed the files; and
- You must retain, in the Source form of any Derivative Works that You distribute, all copyright, patent, trademark, and attribution notices from the Source form of the Work, excluding those notices that do not pertain to any part of the Derivative Works; and
- If the Work includes a **"NOTICE"** text file as part of its distribution, then any Derivative Works that You distribute must include a readable copy of the attribution notices contained within such NOTICE file, excluding those notices that do not pertain to any part of the Derivative Works, in at least one of the following places: within a NOTICE text file distributed as part of the Derivative Works; within the Source form or documentation, if provided along with the Derivative Works; or, within a display generated by the Derivative Works, if and wherever such third-party notices normally appear. The contents of the NOTICE file are for informational purposes only and do not modify the License.

You may add Your own attribution notices within Derivative Works that You distribute, alongside or as an addendum to the NOTICE text from the Work, provided that such additional attribution notices cannot be construed as modifying the License. You may add Your own copyright statement to Your modifications and may provide additional or different license terms and conditions for use, reproduction, or distribution of Your modifications, or for any such Derivative Works as a whole, provided Your use, reproduction, and distribution of the Work otherwise complies with the conditions stated in this License.

5. Submission of Contributions. Unless You explicitly state otherwise, any Contribution intentionally submitted for inclusion in the Work by You to the Licensor shall be under the terms and conditions of this License, without any additional terms or conditions. Notwithstanding the above, nothing herein shall supersede or modify the terms of any separate license agreement you may have executed with Licensor regarding such Contributions.

6. Trademarks. This License does not grant permission to use the trade names, trademarks, service marks, or product names of the Licensor, except as required for reasonable and customary use in describing the origin of the Work and reproducing the content of the NOTICE file.

7. Disclaimer of Warranty. Unless required by applicable law or agreed to in writing, Licensor provides the Work (and each Contributor provides its Contributions) on an "AS IS" BASIS, WITHOUT WARRANTIES OR CONDITIONS OF ANY KIND, either express or implied, including, without limitation, any warranties or conditions of TITLE, NON-INFRINGEMENT, MERCHANTABILITY, or FITNESS FOR A PARTICULAR PURPOSE. You are solely responsible for determining the appropriateness of using or redistributing the Work and assume any risks associated with Your exercise of permissions under this License.

8. Limitation of Liability. In no event and under no legal theory, whether in tort (including negligence), contract, or otherwise, unless required by applicable law (such as deliberate and grossly negligent acts) or agreed to in writing, shall any Contributor be liable to You for damages, including any direct, indirect, special, incidental, or consequential damages of any character arising as a result of this License or out of the use or inability to use the Work (including but not limited to damages for loss of goodwill, work stoppage, computer failure or malfunction, or any and all other commercial damages or losses), even if such Contributor has been advised of the possibility of such damages.

9. Accepting Warranty or Additional Liability. While redistributing the Work or Derivative Works thereof, You may choose to offer, and charge a fee for, acceptance of support, warranty, indemnity, or other liability obligations and/or rights consistent with this License. However, in accepting such obligations, You may act only on Your own behalf and on Your sole responsibility, not on behalf of any other Contributor, and

only if You agree to indemnify, defend, and hold each Contributor harmless for any liability incurred by, or claims asserted against, such Contributor by reason of your accepting any such warranty or additional liability.

END OF TERMS AND CONDITIONS

Servicekontakte
Service Contacts
Contacts de Service
Contactos de Servicio



<https://www.bosch-pt.com/serviceaddresses>

Garantiebedingungen
Guarantee Conditions
Conditions de Garantie
Condiciones de Garantía



<https://www.bosch-pt.com/guarantee/202601>